

C AND Z PURLIN



SPECIFICATION

- Z / C Section structural members designed for use as secondary supports for roof sheeting and where applicable insulation and liner trays for spans up to 10.0 m depending on the load to be applied and where the cladding or liner tray offers adequate support by virtue of its fixings i.e., fixed according to sheet manufacturer's instructions.
- Z / C Sections are manufactured from ASTM A653 structural quality pre-hot dipped galvanized sheet to G90 with minimum guaranteed yield strength of 345 N/mm².
- Holes on web and flanges as per customer requirements.

APPLICATIONS

- Secondary support & Girts

SECTION PROFILE

THICKNESS (T) in mm	1.5 – 3.5
SECTION in mm	100 - 305
DEPTH (D) in mm	100 - 305
TOP FLANGE (A) in mm	40 - 90
BOTTOM FLANGE (B) in mm	40 - 90
LIP SIZE (L) in mm	12 – 25

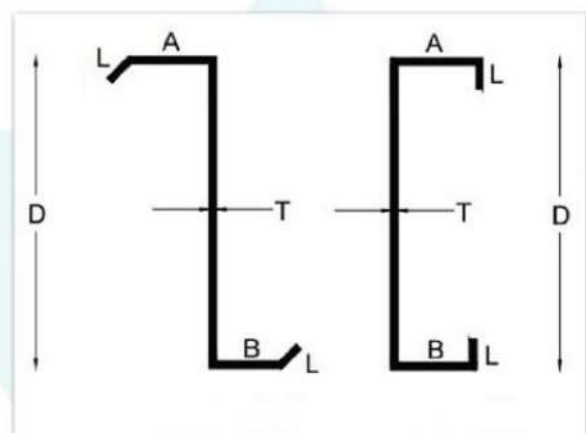

C AND Z PURLIN

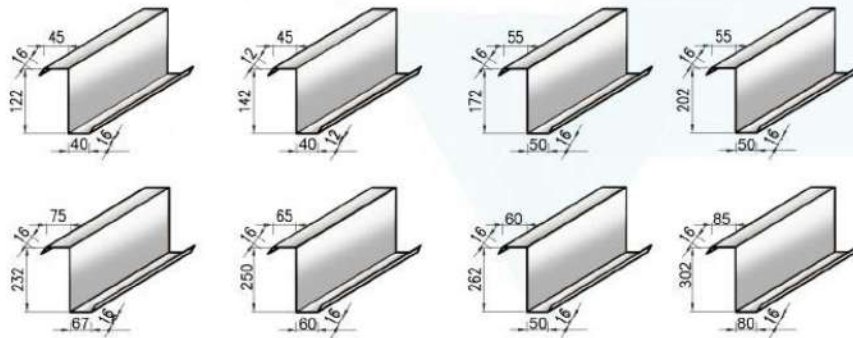

SECTION		12220	14220	17220	20220	23220	25020	26220	30220
Depth	D mm	122	142	172	202	232	250	262	302
Thickness	T mm	2	2	2	2	2	2	2	2
Top Flange	A mm	45	45	55	55	75	65	60	85
Bottom Flange	B mm	40	40	50	50	67	60	50	80
Weight	Kg/m	3.75	3.93	4.85	5.24	6.37	6.37	6.37	7.85
Area	mm ²	432	471	571	631	765	767	761	947
Ixx	cm ⁴	92	133	241	355	595	659	687	1206
Zxx	cm ³	15.5	19.1	28.5	35.7	52.3	53.4	53.85	81.3
Iyy	cm ⁴	8.7	8.7	15.3	15.4	35.4	24.4	18.92	51.7
ryy	mm	19.3	18.47	22.3	21.22	29.1	24	20.7	32.2

SECTION		12215	14215	17215	20215	23215	25015	26215	30215
Depth	D mm	122	142	172	202	232	250	262	302
Thickness	T mm	1.5	1.5	1.5	1.5	1.5	1.5	1.5	1.5
Top Flange	A mm	45	45	55	55	75	65	60	85
Bottom Flange	B mm	40	40	50	50	67	60	50	80
Weight	Kg/m	2.8	2.95	3.63	3.93	4.78	4.78	4.78	5.89
Area	mm ²	327	357	432	477	578	579	574	714
Ixx	cm ⁴	71	102	184	271	452	501	523	914.3
Zxx	cm ³	11.85	14	21.3	27.2	39.8	40.6	40.9	61.6
Iyy	cm ⁴	6.8	6.9	11.87	11.9	27.4	18.9	14.7	39.74
ryy	mm	19.64	18.8	22.65	21.55	29.5	24.74	21	32.55

C AND Z PURLIN



STANDARD PURLIN SERIES

SLEEVES

CLEATS

